



# GT4000ESi ELECTRIC START INVERTER GENERATOR

## 4000W



### OPERATING INSTRUCTIONS

## Contents

Introduction.....	3
Environmental protection.....	3
Scope of product.....	3
Description of symbols.....	3
Specifications.....	3
Safety instructions.....	4
Know your product.....	8
Unpacking.....	8
Control panel.....	9
Approximate wattage requirements.....	10
Connecting the battery.....	11
Powercords.....	11
Before starting.....	12
Preparation.....	13
Adding engine oil.....	14
Adding fuel.....	14
Starting the generator.....	15
Stopping the generator.....	17
Maintenance.....	18
Cleaning the generator .....	23
Battery replacement.....	24
Storage.....	24
Troubleshooting.....	25
Parts diagram.....	26
Parts list.....	27
Engine parts diagram.....	28
Engine parts list.....	29
Wiring diagram.....	30
Warranty.....	31

## Introduction

Your new GT POWER Generator will more than satisfy your expectations. It has been manufactured under stringent quality standards to meet superior performance criteria. You will find your new tool easy and safe to operate, and, with proper care, it will give you many years of dependable service.

Carefully read through this entire Instruction Manual before using your new GT POWER Generator. Take special care to heed the cautions and warnings.

Your generator has many features that will make your job faster and easier. Safety, performance, and dependability have been given top priority in the development of this tool, making it easy to maintain and operate.

## Environmental Protection

Recycle unwanted materials instead of disposing of them as waste. All tools, hoses and packaging should be sorted, taken to the local recycling centre and disposed of in an environmentally safe way.



## Scope Of Product

This product is suited for home, camping and emergency power applications. It will operate most powertools, appliances and lighting.

## Description Of Symbols

The rating plate on your tool may show symbols. These represent important information about the product or instructions on its use.



Wear hearing protection.  
Wear eye protection.  
Wear breathing protection.



Conforms to relevant standards for electromagnetic compatibility.

## Specifications

AC Output:	230V AC ~ 50Hz
Rated Power:	3500W
Peak Power:	4000W
Phase:	Single
Displacement:	225cc
Engine:	7HP, 4 stroke OHV
No Load Speed:	3600 RPM
Fuel Tank Capacity:	12L
Fuel Type:	Unleaded petrol
Oil Type:	SAE10W-30 4 Stroke
Operation Noise Level:	52dB
Net Weight:	40kg
Starting system:	Electric/Recoil
Run Time:	12hrs @ 50 % load
Dimensions:	758 x 495 x 550
Power Outlets:	2

## Safety Instructions

To use this tool properly, you must observe the safety regulations, the assembly instructions and the operating instructions to be found in this Manual. All persons who use and service the machine have to be acquainted with this Manual and must be informed about its potential hazards. Children and infirm people must not use this tool. Children should be supervised at all times if they are in the area in which the tool is being used. It is also imperative that you observe the accident prevention regulations in force in your area. The same applies for general rules of occupational health and safety.

---

**⚠ WARNING:**  
*When using power tools, basic safety precautions should always be taken to reduce the risk of fire, electric shock and personal injury. Also, please read and heed the advice given in the additional important safety instructions.*

---

- 1. Keep the work area clean and tidy.** Cluttered work areas and benches invite accidents and injury.
- 2. Consider the environment in which you are working.** Do not use power tools in damp or wet locations. Keep the work area well lit. Do not expose power tools to rain. Do not use power tools in the presence of flammable liquids or gases.
- 3. Keep visitors away from the work area.** All visitors and onlookers, especially children and infirm persons, should be kept well away from where you are working. Do not let others in the vicinity make contact with the tool or extension cord.
- 4. Store tools safely.** When not in use, tools should be locked up out of reach.
- 5. Do not force the tool.** The tool will do the job better and safer working at the rate for which it was designed.
- 6. Use the correct tool for the job.** Do not force small tools or attachments to do the job best handled by a heavier duty tool. Never use a tool for a purpose for which it was not intended.

**7. Dress correctly.** Do not wear loose clothing or jewellery. They can be caught in moving parts. Rubber gloves and non-slip footwear are recommended when working outdoors. If you have long hair, wear a protective hair covering.

**8. Use safety accessories.** Safety glasses and earmuffs should always be worn. A face or dust mask is also required if the drilling operation creates dust.

**9. Secure the work piece.** Use clamps or a vice to hold the work piece. It is safer than using your hand and frees both hands to operate the tool.

**10. Do not overreach.** Keep your footing secure and balanced at all times.

**11. Look after your tools.** Keep tools sharp and clean for better and safer performance. Follow the instructions regarding lubrication and accessory changes. Inspect tool cords periodically and, if damaged, have them repaired by an authorised service facility. Inspect extension cords periodically and replace them if damaged. Keep tool handles dry, clean and free from oil and grease.

**12. Remove adjusting keys and wrenches.** Check to see that keys and adjusting wrenches are removed from the tool before switching on.

**13. Stay alert.** Watch what you are doing. Use common sense. Do not operate a tool when you are tired.

**14. Check for damaged parts.** Before using a tool, check that there are no damaged parts. If a part is slightly damaged, carefully determine if it will operate properly and perform its intended function. Check for alignment of moving parts, binding of moving parts, breakage of parts, proper mounting and any other conditions that may affect the operation of the tool. A part that is damaged should be properly repaired or replaced by an authorised service facility, unless otherwise indicated in this Instruction Manual.

**15. Use only approved parts.** When servicing, use only identical replacement parts. Use an authorised service facility to fit replacement parts.

---

**⚠ WARNING:**  
*The use of an accessory or attachment, other than those recommended in this Instruction Manual, may present a risk of personal injury.*

---

Save these important safety instructions

Risk of electrocution and fire		
Hazard	What could happen	How to prevent it
Improper storage of extension cord.	Extension cord can come into contact with hot engine parts resulting in damage. Using a damaged extension cord can result in electrocution or death.	Remove extension cord from the generator and store separately away from generator.
Operation of generator in rain, wet, icy, or flooded conditions.	Water is an excellent conductor of electricity! Water which comes in contact with electrically charged components can transmit electricity to the frame and other surfaces, resulting in electrical shock to anyone contacting them.	Operate generator in a clean, dry, well ventilated area. Make sure hands are dry before touching unit.
Placing generator on or against highly conductive surface, such as a steel walkway or metal roof.	Accidental leakage of electrical current could charge conductive surfaces in contact with the generator.	Place generator on low conductivity surface such as a concrete slab. <b>ALWAYS</b> operate generator a minimum of 2 meters from any conductive surface.
Use of worn, damaged or ungrounded extension cords.	Contact with worn or damaged extension cords could result in electrocution. Use of ungrounded cordsets could prevent operation of circuit breakers and result in electrical shock.	Inspect extension cords before use and replace with new cord if required. Always use a cordset having a grounding wire with an appropriate grounding plug. <b>DO NOT</b> use an ungrounded plug.
Operation of unit when damaged, or with guards or panels removed.	Attempting to use the unit when it has been damaged, or when it is not functioning normally could result in fire or electrocution. Removal of guarding could expose electrically charged components and result in electrocution.	Do not operate generator with mechanical or electrical problem. Have unit repaired by an Authorized Service Centre. Do not operate generator with protective guarding removed.

Risk of fire		
Hazard	What could happen	How to prevent it
Attempting to fill the fuel tank while the engine is running.	Fuel and fuel vapours can become ignited by coming in contact with hot components such as the muffler, engine exhaust gases, or from an electrical spark.	Turn engine off and allow it to cool before adding fuel to the tank. Equip area of operation with a fire extinguisher certified to handle gasoline or fuel fires.
Sparks, fire, hot objects	Cigarettes, sparks, fires, or other hot objects can cause fuel or fuel vapours to ignite.	Add fuel to tank in well ventilated area. Make sure there are no sources of ignition near the generator.
Improper storage of fuel	Improperly stored fuel could lead to accidental ignition. Fuel improperly secured could get into the hands of children or other unqualified persons.	Store fuel in an approved container designed to hold fuel. Store container in secure location to prevent use by others.
Tampering with factory set engine speed settings.	Engine speed has been factory set to provide safe operation. Tampering with the engine speed adjustment could result in overheating of attachments and could cause a fire.	Never attempt to "speed-up" the engine to obtain more performance. Both the output voltage and frequency will be thrown out of standard by this practice, endangering attachments and the user.
Inadequate ventilation for generator	Materials placed against or near the generator or operating the generator in areas where the temperature exceeds 40° C ambient (such as storage rooms or garages) can interfere with its proper ventilation features causing overheating and possible ignition of the materials or buildings.	Operate generator in a clean, dry, well ventilated area.  <b>DO NOT OPERATE UNIT INDOORS OR IN ANY CONFINED AREA.</b>

<p><b>Overfilling the fuel tank – fuel spillage.</b></p>	<p>Spilled fuel and its vapours can become ignited from hot surfaces or sparks.</p>	<p>Use care in filling the tank to avoid spilling fuel. Make sure fuel cap is secured tightly and check engine for fuel leaks before starting engine. Move generator away from refuelling area or any spillage before starting engine. Allow for fuel expansion. Never refuel with the engine running.</p>
--	---	--

<b>Risk of injury and property damage when transporting generator</b>		
<b>Hazard</b>	<b>What could happen</b>	<b>How to prevent it</b>
<p><b>Fire, Inhalation, Damage to Vehicle Surfaces</b></p>	<p>Fuel or oil can leak or spill and could result in fire or breathing hazard, serious injury or death can result. Fuel or oil leaks can damage carpet, paint or other surfaces in vehicles or trailers.</p>	<p>The generator is equipped with a fuel tap, turn the lever of this valve to the off position before transporting to avoid fuel leaks. Transport fuel only in an approved fuel container. Always place generator on a protective mat when transporting to protect against damage to vehicle from leaks. Remove generator from vehicle immediately upon arrival at your destination.</p>

<b>Risk of breathing - inhalation hazard</b>		
<b>Hazard</b>	<b>What could happen</b>	<b>How to prevent it</b>
<p><b>Gasoline engines produce toxic carbon monoxide exhaust fumes.</b></p>	<p>Breathing exhaust fumes will cause serious injury or death.</p>	<p>Operate generator in clean, dry, well ventilated area. Never operate unit in enclosed areas such as garages, basements, storage, sheds, or in any location occupied by humans or animals. Keep children, pets and others away from area of operating unit.</p>

<b>Risk of unsafe operation</b>		
<b>Hazard</b>	<b>What could happen</b>	<b>How to prevent it</b>
<p><b>Operation of generator in careless manner.</b></p>	<p>All sources of energy include the potential for injury. Unsafe operation or maintenance of your generator could lead to serious injury or death to you or others.</p>	<ul style="list-style-type: none"> <li>• Review and understand all of the operating instructions and warnings in this manual.</li> <li>• Become familiar with the operation and controls of the generator. Know how to shut it off quickly.</li> <li>• Equip area of operation with a fire extinguisher certified to handle gasoline or fuel fires.</li> <li>• Keep children or others away from the generator at all times.</li> </ul>
<p><b>Operating generator while suspended</b></p>	<p>Generator will not operate properly and will cause damage to the generator and could cause serious injury or death to you or others.</p>	<p>Never operate generator while suspended or in an unlevel position. Always operate generate on a flat, level surface.</p>

Risk of hot surfaces		
Hazard	What could happen	How to prevent it
Contact with hot engine and generator components.	Contact with hot surfaces, such as engines exhaust components, could result in serious burns.	During operation, touch only the control surfaces of the generator. Keep children away from the generator at all times. They may not be able to recognize the hazards of this product.

Risk of moving parts		
Hazard	What could happen	How to prevent it
Contact with moving parts can result in serious injury.	The generator contains parts which rotate at high speed during operation. These parts are covered by guarding to prevent injury.	Never operate generator with guarding or cover plates removed. Avoid wearing loose fitting clothing or jewellery which could be caught by moving parts.

Risk from lifting		
Hazard	What could happen	How to prevent it
Lifting a very heavy object.	Serious injury can result from attempting to lift too heavy an object.	When lifting, always keep the object you are lifting near the vertical axis of your body. DO NOT use you back to lift heavy loads. Both people should crouch down, grab the underside of unit and use your legs to carry the weight. Keep the object as near the centre of your body's gravity as possible. Avoid twisting your bodies when carrying the unit; instead, turn your whole body using your feet.

- 1. Do not operate in a hazardous location.** Such areas include where there is a risk of explosion of petrol fumes, leaking gas or explosive dust.
- 2. Do not operate in a confined area.** Exhaust gases, smoke or fumes could reach dangerous concentrations.
- 3. The output of this generator is potentially lethal.** The generator should not be connected to a fixed electrical installation except by an appropriately licensed person.
- 4. Protect your generator.** This generator is NOT WEATHERPROOF and should not be exposed to direct sunlight, high ambient temperature and damp, wet or high humidity conditions.
- 5. Do not smoke while refuelling.** This is potentially dangerous as it may ignite the fuel and cause an explosion.
- 6. Take care not to spill fuel.** When refuelling the generator ensure that the engine has been switched off. Prevent the spilling of fuel as this may

also ignite with the hot engine. Never refuel whilst the engine running.

- 7. Be careful where you store the generator.** Store the generator in a dry area away from inflammable liquids.
- 8. Keep your distance.** The generator emits exhaust fumes. As a safety precaution do not stand close to the unit whilst it is in operation. Ensure bystanders also keep their distance.
- 9. Never fill fuel tank indoors.** Never fill fuel tank when engine is running or hot. Do not smoke when filling fuel tank.
- 10. Never operate the generator if powered items overheat.** Or when electrical output drops, there is sparking, flames or smoke coming from the generator, or if the receptacles are damaged.
- 11. Never use the inverter to power medical support equipment.**

12. Always remove any tools or other service equipment used during maintenance from the generator before operating.

**NOTE:** Never modify the inverter. Never operate the inverter if it vibrates at high levels, if engine speed changes greatly or if the engine misfires often.

**⚠ WARNING!**  
 You **MUST** unplug any load from the generator before starting and stopping to prevent permanent damage to any appliances.

## Unpacking

### Parts Included:

Your generator ships with the following parts:

- |                              |            |
|------------------------------|------------|
| 1 x Spark Plug Socket Wrench | 1 x Funnel |
| 1 x Engine Oil               | 1 x Manual |
| 1 x Quick Start Guide        |            |

Due to modern mass production techniques, it is unlikely that your GT POWER Generator is faulty or that a part is missing. If you find anything wrong, do not operate the tool until the parts have been replaced or the fault has been rectified. Failure to do so could result in serious personal injury.

## Know Your Product

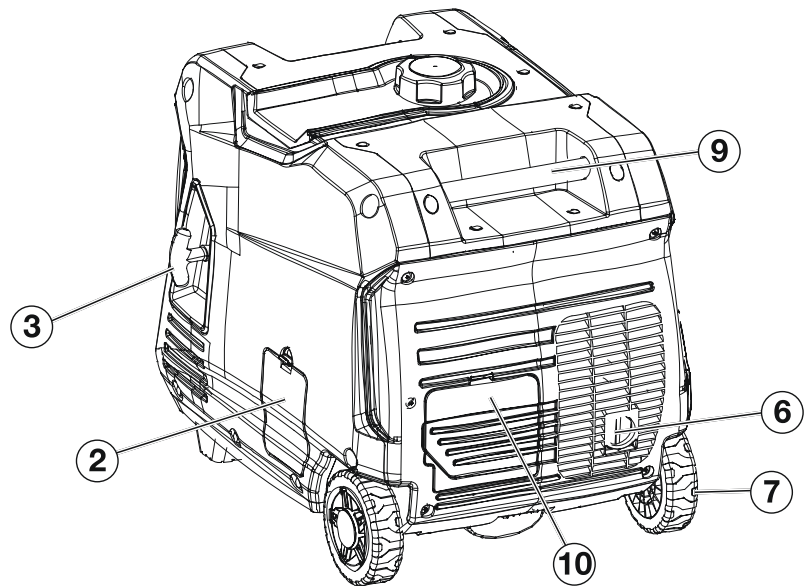
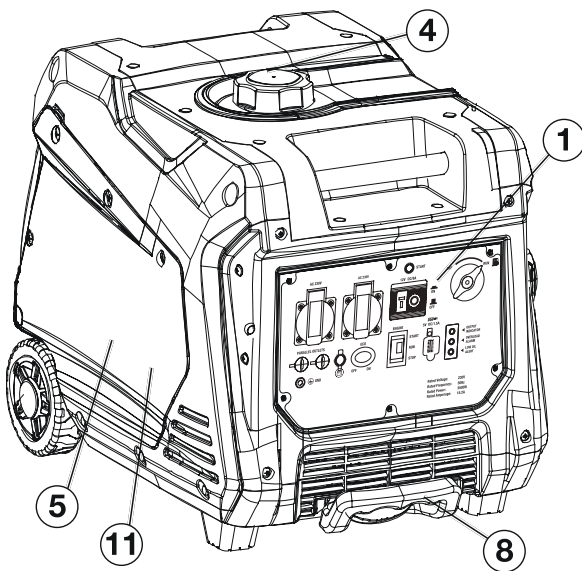

1. **Control Panel:** Contains the reset breaker, outlets and warning lights.
2. **Oil Access Cover:** Remove the cover to access the oil fill/drain plug.
3. **Recoil Handle:** Pull to manually start the engine.
4. **Fuel Cap:** Close until clicking sound is heard.
5. **Engine Service Panel:** Remove the panel to access the engine, choke, air filter, spark plug and float bowl for maintenance.
6. **Muffler and Spark Arrestor:** Avoid contact until the engine is cooled down.

The spark arrestor prevents sparks from exiting the muffler. It must be removed for servicing.

7. **Roller Board Wheels:** For easy portability.
8. **Telescopic Handle:** Extends and retracts for easy access.
9. **Carry Handles:** Built in handles to allow for easy pick up.
10. **Battery Access Panel:** Easy access to battery.
11. **Automatic Choke:** Unit will automatically set choke for electric and manual start (if battery is dead or disconnected you have to set choke manually)



## Control Panel

1. 230V, 15A Single Phase Outlet Socket x 2:
2. 12V DC/8A Plug
3. Start Indicator Light
4. **Engine Control Switch:** Turn to CHOKE position to start engine, then turn to RUN position once engine is running. Switch to OFF to stop generator.
5. **LED Indicator Lights:** See next section.
6. **USB Duplex:** 5V DC
7. **Engine Switch**
8. **ECO Mode Switch:** Efficiency switch when turned to the ON position, the engine will sense the load needed and run at a slower RPM to save fuel.
9. **Battery Outlet**
10. **Parallel Outlets:** Optional Cables connect 2 x GT POWER machines to increase power output. *DO NOT attempt to parallel the GT POWER generator with any other manufacturers' generators.* See pg 12 for more information.
11. **Ground Terminal:** The ground terminal is used to externally ground the generator.

## LED Light Indicators

- A. OUTPUT READY INDICATOR:** The output ready indicator shows a green light when the generator is operating normally and producing electrical power to the receptacles.
- B. OVERLOAD INDICATOR:** Red light flashes when the unit is close to overloading. If any more load is added when the light is flashing the electrical power will be cut to the receptacles and light will become a constant red. *While the engine is running, disconnect all appliances and hit the RESET breaker on the panel. Reduce the amount of appliances before plugging back in.*
- C. LOW OIL INDICATOR:** LED Lights up red when unit is low or out of oil. Engine will not run when indicator is lit. *When this light appears confirm engine is off, let the unit cool down, then add oil. Make sure to periodically check oil levels while filling to prevent overfilling.*

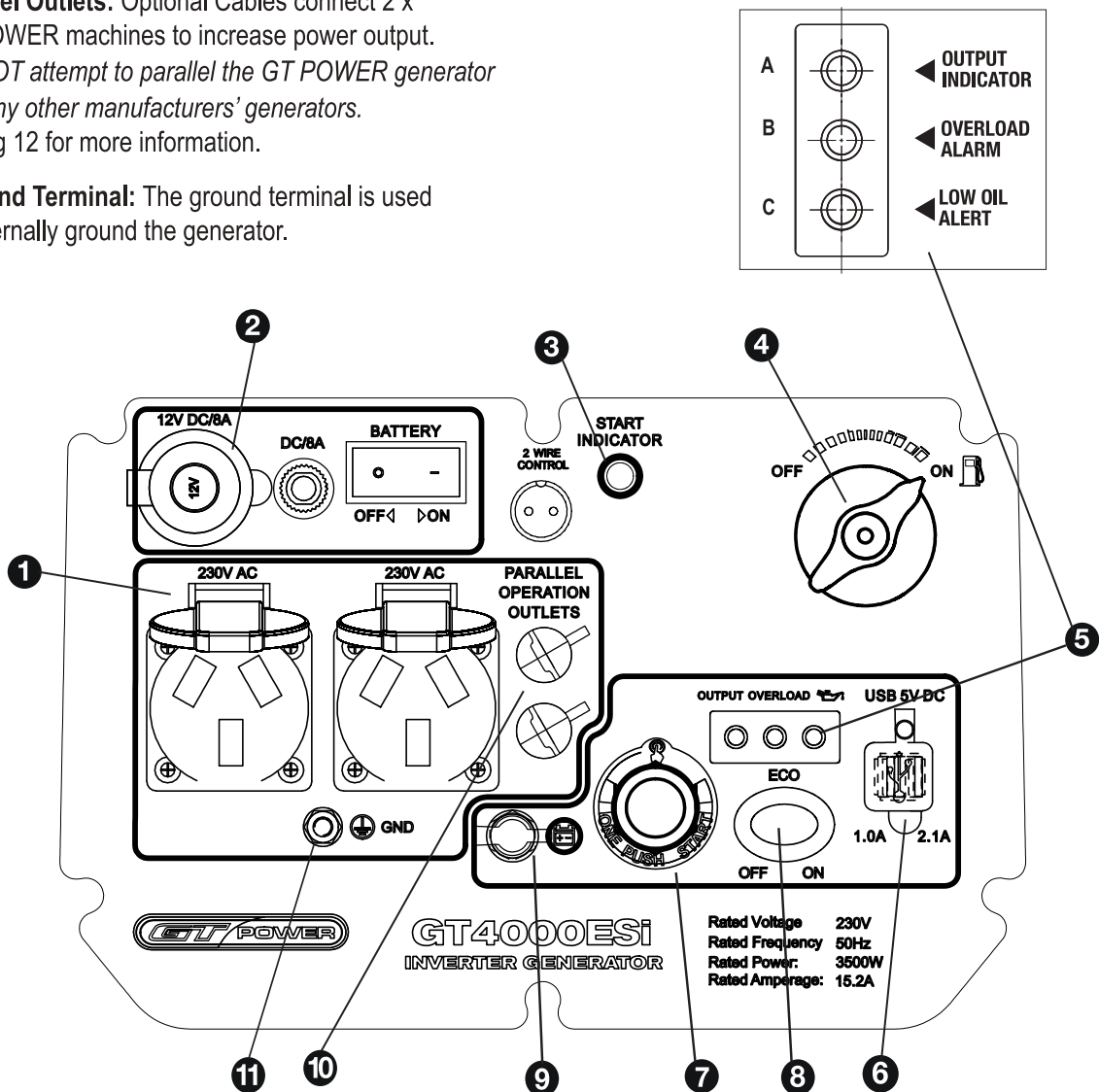

## Approximate Wattage Requirements

**IMPORTANT:** Always check that the combined load of your appliances does not exceed the rated output of your generator. Always select a generator that has more capacity than your load requirements. The small amount extra you may invest to do this will be quickly recovered with the fuel saving and longer service life gained by not having to constantly run your generator at full load.



This chart lists average power requirements. Your particular tool or appliance may require more or less than the listed wattage. \* Where START wattage is the same as RUN wattage, this signifies no additional power is required for starting.

APPLIANCES / TOOLS	APPROX. RUN (W)	APPROX. START (W)
Microwave 750W	750	1200
Coffee Maker	1750	1750
Electric Clothes Drier	5750	5750
Washing Machine	1150	2300
Refrigerator	700	2200
Lights	100	100
Colour Television	350	350
Electric Frypan	1500	1500
Dehumidifier	400	400
Computer - Desktop	700	700
VCR	50	50
Dishwasher - Cool Dry	700	1400
- Hot Dry	1450	2000
Toaster - 2 Slice	1250	1250
- 4 Slice	1600	1600
Freezer	2200	2500
Hair Dryer	800-1700	800-1700
Steam Iron	1800	1800
Garage Door Opener - 1/4 HP	550	1100
- 1/3 HP	725	1400
Radio	200	200
Blender	375	500
Sump Pump 1/2 HP	1050	2150
Well Pump 1/2 HP	1000	2100
Household Water Pump	1200	2700

APPLIANCES / TOOLS	APPROX. RUN (W)	APPROX. START (W)
Central Air Conditioner:		
10,000 BTU	1500	2200
24,000 BTU	3800	5000
32,000 BTU	5000	6500
Room Air Conditioner:		
10,000 BTU	1500	2200
Circular Saw 7 1/4"	1400	2300
Chainsaw 2HP	1100	2500
Portable Air Compressor	1200	3600
Hand Drill 1/2"	600	600
Drill 1/2"	600	900
Battery Charger 15 amp	500	700
Electric Welder 200 amp AC	9000	9000
Jigsaw	300	400
Electric Weed Trimmer	500	650
Router	1000	1300
Belt Sander	1000	1300
Table Saw 10"	1750	4250
Bench Grinder	1400	2450
Concrete Mixer 3.5c/f	1900	2500
Band Saw	1100	1350
Power Drill - Medium	1000	1200
- Heavy Duty	1500	1800
Angle Grinder - 100mm	1000	1200
- 230mm	2400	2700

## Connecting the Battery



### WARNING!

To avoid electric shock:

- ALWAYS connect the positive (+) battery cable (red boot) first when connecting battery cables.
- ALWAYS disconnect the negative (-) battery cable (black boot) first when disconnecting battery cables.
- NEVER connect the negative (-) battery cable (black boot) to the positive (+) post on the battery.
- NEVER connect the positive (+) battery cable (red boot) to the negative (-) post on the battery.
- NEVER touch both battery posts simultaneously.
- NEVER place a metal tool across both battery posts.
- ALWAYS use insulated or non-conducting tools when installing the battery.

**NOTE:** The inverter comes equipped with the positive battery cable (red boot) already attached.

1. Unclip the battery access panel on the back of the unit next to the muffler (see Figure 1).

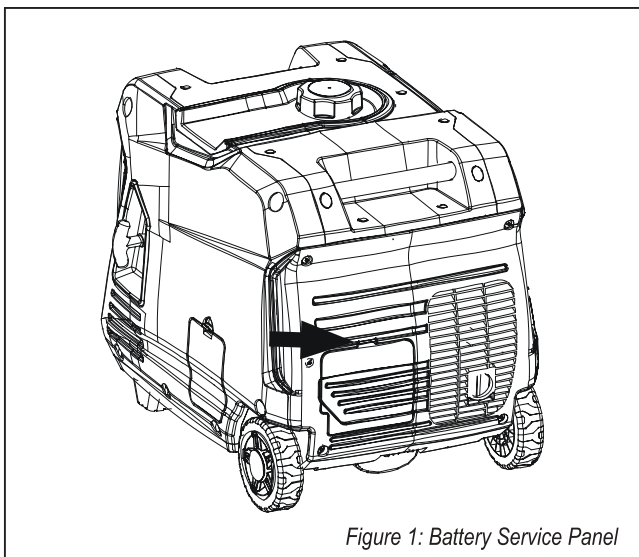

Figure 1: Battery Service Panel

2. Verify the positive (+) battery cable (red boot) is securely tightened to the positive (+) battery post. Make sure boot is over battery post.
3. Carefully remove the protective wrapping around the lug of the negative (-) battery cable (black boot).
4. Locate negative (-) cable attached to alternator cable, remove tie and route to the negative (-) battery post.
5. Pull back the black boot and securely attach the negative (-) battery cable (black boot) to the negative (-) battery post as shown in Figure 2.
6. Replace the black boot so it protects the cable lug and battery post.

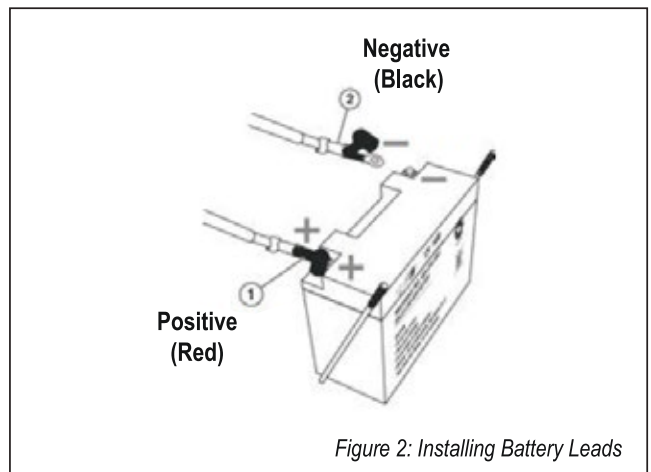

Figure 2: Installing Battery Leads

**NOTE:** The electric start generator is equipped with a battery charging feature. Once the engine is running, a small charge is supplied to the battery via the battery cables and will slowly recharge the battery.

## Powercords

### Using Extension Cords

GT POWER assumes no responsibility for the content within this table (on the following page). The use of this table is the responsibility of the user only. This table is intended for reference only. The results produced by using this table are not guaranteed to be correct or applicable in all situations as the type and construction of cords are highly variable.

Always check with local regulations and a licensed electrician prior to installing or connecting an electrical appliance.

Extension Cord Wire Gauge Size									
AMPS	LENGTH OF EXTENSION CORD (ft)								
	10	20	30	40	50	60	80	100	120
5	20	18	16	14	12	12	10	10	8
10	18	16	14	12	12	10	10	8	8
15	16	14	12	12	10	10	8	8	6
20	14	12	12	10	10	8	8	6	6
25	12	12	10	10	8	8	6	6	6
30	12	10	10	8	8	6	6	6	6
35	10	10	8	8	6	6	6	6	6

## Parallel Connection

The parallel connection is a feature that allows two GT4000ESi machines to be connected together almost doubling the output of one unit. Check your wattage reference guide and be sure the device you are connecting is less than the rated use of this generator in parallel use (see specifications).

Follow instructions in the owner's manual for the parallel connection procedure.

### **⚠ DANGER!**

*Never connect the paralleling cord to the generators when they are running. Both the paralleling cord switches must be off when connecting the cords.*

### **⚠ WARNING!**

*Do not attempt to parallel the Powermax generator with any other manufacturers' generators. Do not use the paralleling cord for any application other than generator paralleling. Do not use this cord on other manufacturers' generators.*

*Always ensure that both ends of the paralleling cord are switched off before connecting.*

## Before Starting

Before starting the inverter, review the safety section in this manual.



## Location Selection

Before starting, avoid exhaust and location hazards by verifying:

- You have selected a location to operate the generator that is outdoors and well ventilated.
- You have selected a location with a level and solid surface on which to place the generator.
- You have selected a location that is at least 6 feet (1.8 m) away from any building, other equipment or combustible material.
- If the generator is located close to a building, make sure it is not located near any windows, doors and/or vents.

**⚠ DANGER!**  
*Using a generator indoors can kill you in minutes. Generator exhaust contains carbon monoxide. This is a poison you cannot see or smell.*



**NEVER** use inside a home or garage, **EVEN IF** doors and windows are open.



Only use **OUTSIDE** and far away from windows, doors, and vents.

Avoid other generator hazards.  
**READ MANUAL BEFORE USE**

**⚠ WARNING!**  
*Always operate the generator on a level surface. Placing the generator on non level surfaces can cause it to tip over, resulting in fuel and oil spills. Spilled fuel can ignite if it comes in contact with an ignition source such as a very hot surface.*

**NOTE:** Operating the generator on a surface with loose material such as sand or grass clippings can cause debris to be ingested by the generator that could block cooling vents or air intake system.

**Weather** - Never operate your generator outdoors during rain, snow or any combination of weather conditions that could lead to moisture collecting on, in or around the generator.

**Dry Surface** - Always operate on a dry surface free of any moisture.

**No Connected Loads** - Make sure the generator has no connected loads before starting it. To ensure there are no connected loads, unplug any electrical extension cords that are plugged into the control panel receptacles.

**NOTE:** Starting the generator with loads already applied to it could result in damage to any appliance being powered during the brief start-up period.

**Grounding the Inverter Generator** - Consult with your local municipalities for your grounding codes.

**⚠ WARNING!**  
*Be sure the generator is properly connected to earth ground before operating.*

**High Altitude Operation** - Engine power is reduced the higher you operate above sea level. Output will be reduced approximately 3.5% for every 1000ft of increased altitude from sea level. This is a natural occurrence and cannot be adjusted by engine.

Increased exhaust emissions can also result due to increased fuel mixture. Other issues include hard starting, increased fuel consumption and spark plug fouling.

**High Altitude Carburetor Kit Part Number: 140540**

**⚠ WARNING!**  
*Do not rest inverter on exhaust panel. Do not move Generator while it is on. The inverter will be damaged if operated in this manner.*

## Preparation

Before starting, always check the level of:

- Engine oil
- Gasoline in the fuel tank

Once the generator has started and the engine gets warm it is not safe to add gasoline to the fuel tank or engine oil to the engine while the engine is running or the engine and muffler are hot.

**⚠ WARNING!**  
*Internal pressure can build in the engine crank-case while the engine is running. Removing the oil fill plug/ dipstick while the engine is hot can cause extremely hot oil to spray out of the crankcase and can severely burn skin. Allow engine oil to cool for several minutes before removing the oil fill plug/dipstick.*



## WARNING!

Do not operate a device while it is plugged into the 12V DC outlet. Prolonged exposure to engine exhaust can cause serious injury or death. While charging a device do not place on the exhaust side of the generator. Extreme heat caused by exhaust can damage the device, and cause a potential fire hazard.

## Adding Engine Oil

The unit as shipped does not contain oil in the engine. You must add engine oil before starting for the first time.

**NOTE:** Attempting to start the engine without adding engine oil will permanently damage internal engine components.

The engine is equipped with a low oil shutdown switch. If the oil level becomes low, the engine may shut down and not start until the oil is filled to the proper level.

The owner of the generator is responsible to ensure the proper oil level is maintained during the operation of the generator. Failure to maintain the proper oil level can result in engine damage.

1. Unclip and remove the oil service panel to access the oil fill/drain plug (see Figure 3).

Figure 3: Oil Service Panel

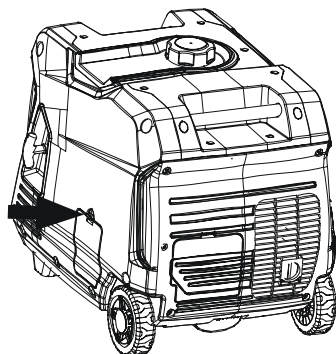

2. Clean area around oil fill/drain plug and remove plug.

3. Using the supplied funnel and oil, pour the entire bottle of oil into the engine. See correct oil level in Figure 4 below.

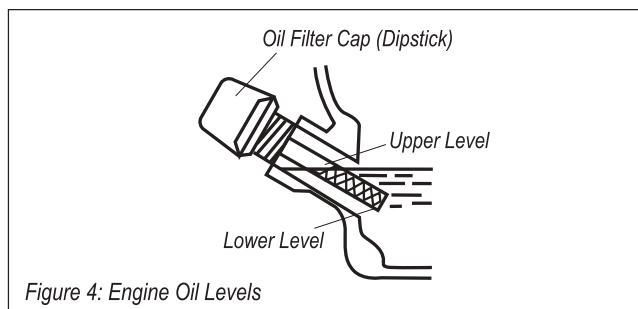

4. Do not overfill, if oil level is too high, oil will drain out through the fill plug.

Only use the engine oil specified in diagram below. Only use 4-stroke/cycle engine oil. NEVER USE 2-STROKE/CYCLE OIL. Synthetic oil is an acceptable substitute for conventional oil.

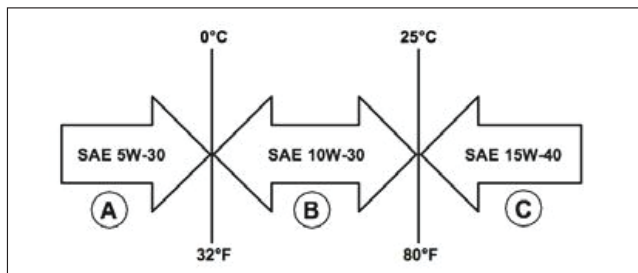

**NOTE:** Before adding engine oil, review safety section earlier in this manual.

Engine oil must be added when the generator is on a flat, level surface, or an inaccurate reading may result. Do not overfill. If the engine is overfilled with oil, it can cause serious engine damage.

## Adding Fuel



### CAUTION!

Avoid prolonged skin contact with gasoline.  
Avoid prolonged breathing of gasoline vapors.



### DANGER!

Filling the fuel tank with gasoline while the generator is running can cause gasoline to leak and come in contact with hot surfaces that can ignite the gasoline.

Only use gasoline that meets the following requirements:

- Unleaded gasoline only
- Gasoline with maximum 10% ethanol added
- Gasoline with an 87 octane rating or higher

Follow the steps below to fill the fuel tank:

1. Shut off the generator.
2. Allow the generator to cool down so all surface areas of the muffler and engine are cool to the touch.
3. Move the generator to a flat surface.
4. Clean area around the fuel cap.
5. Remove the fuel cap by rotating counterclockwise.

**NOTE:** Do not overfill the fuel tank. Spilled fuel will damage some plastic parts.

6. Slowly add gasoline into the fuel tank. Be very careful not to overfill the tank. The gasoline level should NOT be higher than the red ring (see Figure 5).
7. Install the fuel cap by rotating clockwise.

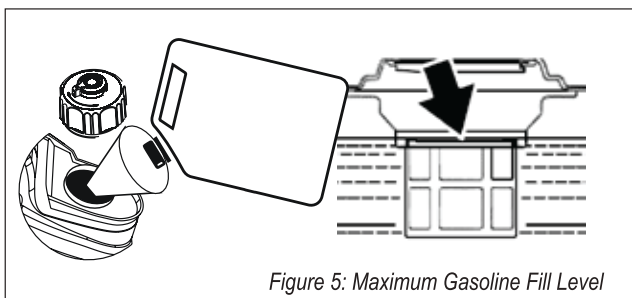

Figure 5: Maximum Gasoline Fill Level

## Starting the Generator

**NOTE:** before starting the inverter, review safety section in this manual.

For proper starting and operation of the inverter, make sure you review the inverter features and their descriptions starting on page 8.

Before attempting to start the generator, verify the following:

- The engine is filled with engine oil (see Figure 4: Engine Oil Correct Level on page 14).
- The generator is situated in a proper location (see Location Selection on page 13).
- The generator is on a dry surface (see Weather and Dry Surface on page 13).
- All loads are disconnected from the generator (see No Connected Loads on page 13).
- The generator is properly grounded (see Grounding the generator on page 13)

### DANGER!

Never use the generator in a location that is wet or damp. Never expose the generator to rain, snow, water spray or standing water while in use. Protect the generator from all hazardous weather conditions. Moisture or ice can cause a short circuit or other malfunction in the electrical circuit.

Never operate in an enclosed area. Engine exhaust contains carbon monoxide. Only operate the inverter outside and away from windows, doors and vents.

## Electric Start

1. Check oil levels (see Adding Engine Oil on page 14)
2. Make sure nothing is plugged into any of the outlets.
3. Make sure battery is connected (see Installing the Battery on page 14).
4. Make sure the circuit breakers are properly set.

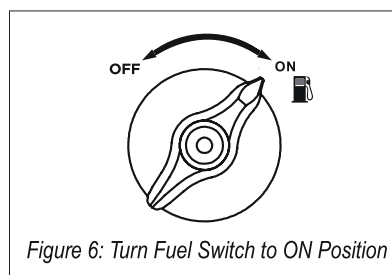

Figure 6: Turn Fuel Switch to ON Position

5. Turn the Fuel Control Switch to the ON position (see Figure 6).

6. Turn battery switch ON.
7. Push and hold the engine start push button for 1 second and release (see Figure 7). The engine will automatically set the choke and begin the start sequence.

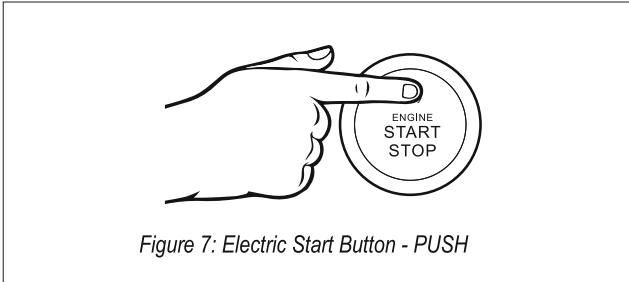

Figure 7: Electric Start Button - PUSH

8. Plug in electronic devices.

**NOTE:** If the engine fails to start after 5 seconds, release button and let generator sit idle for 15 seconds, then repeat step 7. If cranking speed drops after each unsuccessful attempt, then battery may not be adequately charged.

### Manual Start

1. Check oil levels (see Adding Engine Oil on page 14)
2. Make sure nothing is plugged into any of the outlets.
3. Make sure battery is connected (see Installing the Battery on page 14).
4. Turn the Fuel Control Switch to the ON position (see Figure 6).
5. Turn the battery switch ON.
6. Firmly grasp and pull the recoil handle slowly until you feel increased resistance. At this point, apply a rapid pull while pulling out from the generator (see Figure 8).
7. Plug in electronic devices.

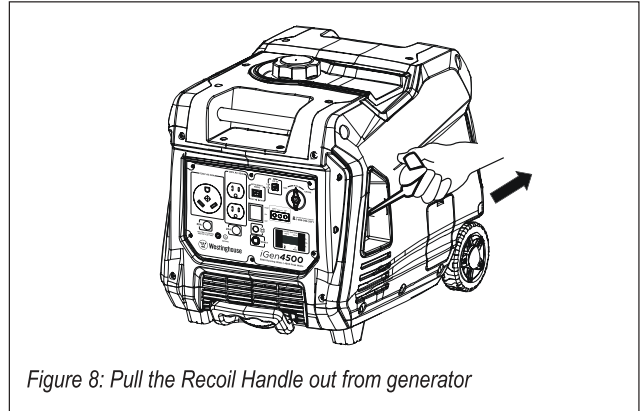

Figure 8: Pull the Recoil Handle out from generator

### Wireless Remote Start

1. Check oil levels (see Adding Engine Oil page 14)
2. Battery must be connected for auto choke to work.
3. Confirm that the Fuel Control Switch is in the ON position (see Figure 6).
4. Push the START icon on the wireless remote. (see Figure 9).

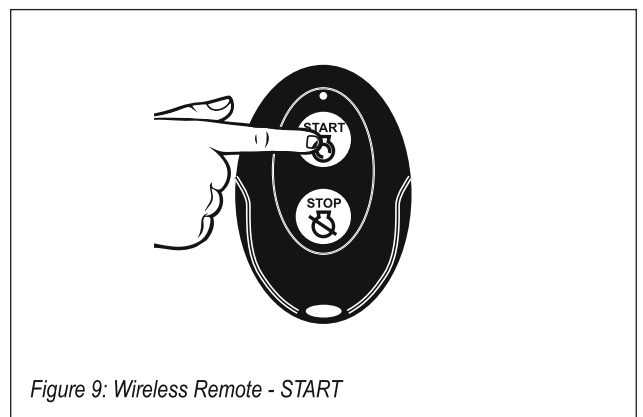

Figure 9: Wireless Remote - START



## Stopping the Generator

### Normal Operation

During normal operation, use the following steps to stop your machine.

1. Remove any connected loads from the control panel receptacles.
2. Allow the generator to run at "no load" to reduce and stabilize engine and alternator temperatures.
3. Move the Fuel Control Switch to the OFF position, press "Stop" on remote start key fob, or press the push button start once (see Figure 10).

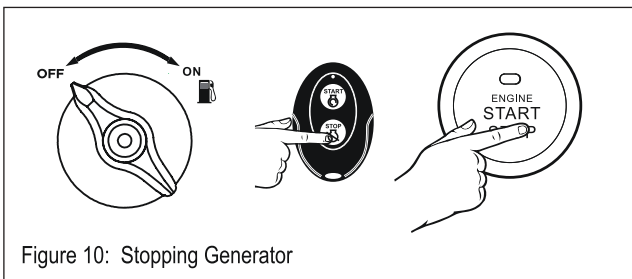

Figure 10: Stopping Generator

### During an Emergency

If there is an emergency and the generator must be stopped quickly, move the Fuel Control Switch to the OFF position immediately.

### Using Efficiency Mode

The generator is equipped with an efficiency mode switch to minimize fuel consumption. In efficiency mode, the generator will sense the load and adjust the engine RPM to the current load requirements.

Efficiency mode should be used only after the generator has been warmed up to operating temperature.

1. To turn on the efficiency mode, press the switch to the ON position).
2. If no load is present, the generator RPM will drop down to an idle speed.
3. As a load is applied, the generator will sense the load and engine RPM will increase according to the load applied.
4. To run the generator at maximum power and RPM, press the efficiency mode switch to the OFF position.

### Resetting the Reset Breaker

The generator will trip the breaker and automatically disconnect from the load when the controls sense a predetermined overload condition. The generator engine will continue to run, but there will not be any electrical output.

1. Turn off all devices and unplug them from the generator.
2. Determine the wattage required from the devices being powered by the generator. Make sure the wattage required does not exceed the maximum output of the generator.
3. Stop and restart the machine
4. Plug the devices in to the generator.
5. Turn on the devices as needed.

## OPERATION INSTRUCTIONS FOR TWO WIRE CONTROL

1. Two wire control switch is pressed ON, one -key start, the remote control and ATS cannot control the start of the generator set. Only the two wire control socket (two-core aviation socket) can control the start and stop the generator set. Test the connection of the two-core aviation socket, the generator set is started, and the generator set is turned off when disconnected.
2. When the two wire control switch is pressed OFF, one -key start, the remote control and ATS can control the start of the generator set. But the two wire control socket cannot control the start and stop of the generator set.

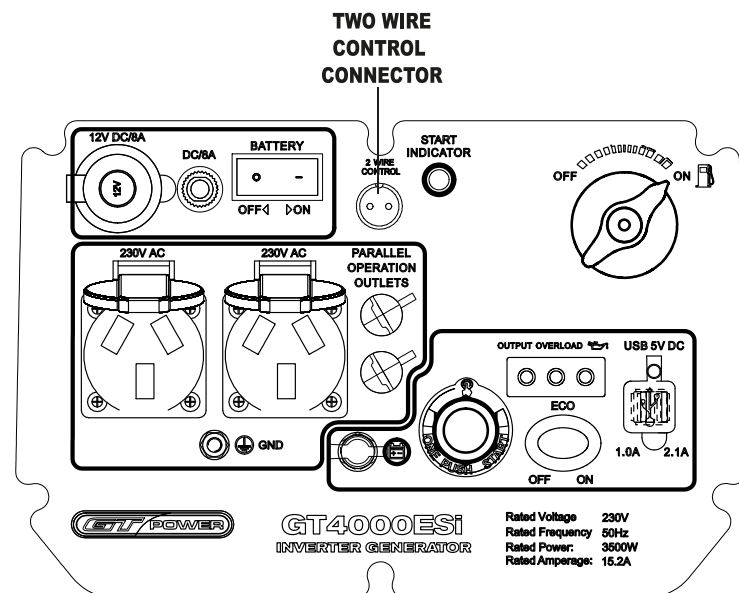

## Maintenance

**Note:** Before performing maintenance on the generator, review the safety section in this manual as well as the following safety messages.



### WARNING!

Avoid accidentally starting the generator during maintenance by removing the spark plug boot from the spark plug. For electric start generators, also disconnect the battery cables from the battery (disconnect the black negative (-) cable first) and place the cables away from the battery posts to avoid arcing.

Allow hot components to cool to the touch prior to performing any maintenance procedure. Internal pressure can build in the engine crank-case while the engine is running.



### WARNING!

Removing the oil fill plug/dipstick while the engine is hot can cause extremely hot oil to spray out of the crankcase and can severely burn skin. Allow engine oil to cool for several minutes before removing the oil fill plug/dipstick.



### WARNING!

Always perform maintenance in a well ventilated area. Gasoline fuel and fuel vapors are extremely flammable and can ignite under certain conditions.



### CAUTION!

Avoid skin contact with engine oil or gasoline. Prolonged skin contact with engine oil or gasoline can be harmful. Frequent and prolonged contact with engine oil may cause skin cancer.

Take protective measures and wear protective clothing and equipment. Wash all exposed skin with soap and water.



### WARNING!

Failure to perform periodic maintenance or not following maintenance procedures can cause the generator to malfunction and could result in death or serious injury.

**NOTE:** Periodic maintenance intervals vary depending on generator operating conditions.

Operating the generator under severe conditions, such as sustained highload, high-temperature, or unusually wet or dusty environments, will require more frequent periodic maintenance.

Following the maintenance schedule below is important to keep the generator in good operating condition.

On the following page is a summary of maintenance items by periodic maintenance intervals which should be treated as a guideline.

## Maintenance Schedule

Maintenance Item	Before Every Use	After First 20 Hours or First Month of Use	After 50 Hours of Use or Every 6 Months	After 100 Hour of Use or Every 6 Months	After 300 Hours of Use or Every Year
Engine Oil	Check Level	Change	Change	-	-
Cooling Features	Check/Clean	-	-	-	-
Air Filter	Check	-	Clean*	-	Replace
Spark Plug	-	-	-	Check/Clean	Replace
Spark Arrestor	-	-	-	Check/Clean	-

\*Service more frequently if operating in dry and dusty conditions

## Engine Oil Maintenance

**NOTE:** Always maintain proper engine oil level. Failure to maintain proper engine oil level could result in severe damage to the engine and/or shorten the life of the engine.

Always use the specified engine oil. Failure to use the specified engine oil can cause accelerated wear and/or shorten the life of the engine.

Engine oil level should be checked before every use. See page 14 for more information

### CAUTION!

*Only use 4-stroke/cycle engine oil.  
NEVER USE 2-STROKE/CYCLE OIL.  
Synthetic oil is an acceptable substitute for  
conventional oil.*

## Checking Engine Oil

**NOTE:** Always maintain proper engine oil level. Failure to maintain proper engine oil level could result in severe damage to the engine and/or shorten the life of the engine. Always use the specified engine oil. Failure to use the specified engine oil can cause accelerated wear and/or shorten the life of the engine.

Engine oil level should be checked before every use.

1. Always operate or maintain the generator on a flat surface.
2. Stop engine if running.
3. Let engine sit and cool for several minutes (allow crankcase pressure to equalize).
4. Remove the engine service panel to access the oil fill/drain plug.
5. With a damp rag, clean around the oil fill/drain plug.
6. Remove the oil fill/drain plug.

7. Check oil level: When checking the engine oil, remove the oil fill/ drain plug.

- The oil level is acceptable if oil is visible at the bottom of the threads of the oil fill plug.
- If oil level is low, add to the correct level using the supplied oil fill bottle. Do not overfill the oil crankcase.

## Adding Engine Oil

See page 14 for information on adding engine oil.

## Changing Engine Oil

1. Stop the engine.
2. Let engine sit and cool for several minutes (allow crankcase pressure to equalize).
3. Remove the engine service panel to gain access to the oil fill/drain plug.
4. Place oil pan (or suitable container) under the oil fill/drain plug.
5. Remove oil fill/drain plug. With a damp rag, thoroughly clean around the oil fill/drain plug.
6. Insert provided funnel around oil fill/drain and carefully tilt the generator so the oil drains down through the funnel into the container.
7. Allow oil to completely drain.
8. Fill crankcase with oil following the steps outlined in Adding Engine Oil on page 14 and tighten oil plug.
9. Dispose of used engine oil properly.

## Cleaning the Air Filter

**⚠ CAUTION!**  
*Never use gasoline or other flammable solvents to clean the air filter. Use only household detergent soap to clean the air filter.*

The air filter must be cleaned after every 50 hours of use or 3 months (frequency should be increased if generator is operated in a dusty environment).

1. Turn off the generator and let it cool for several minutes if running.
2. Remove the engine service panel to gain access to the air filter. (See Figure 11).
3. Turn the 2 knobs on the air cleaner to unlock the cover. Tip the cover down to access the foam element (see Figure 12).

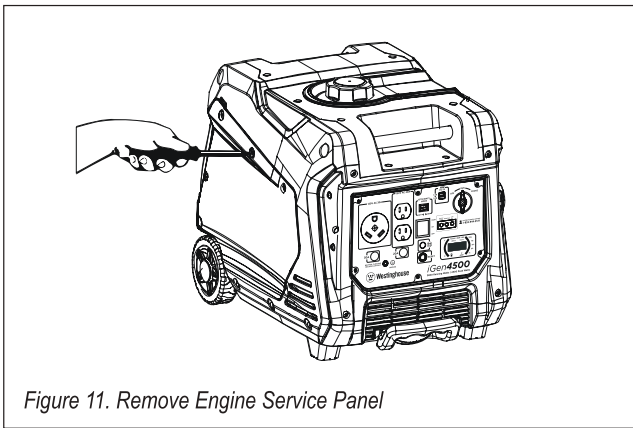

Figure 11. Remove Engine Service Panel

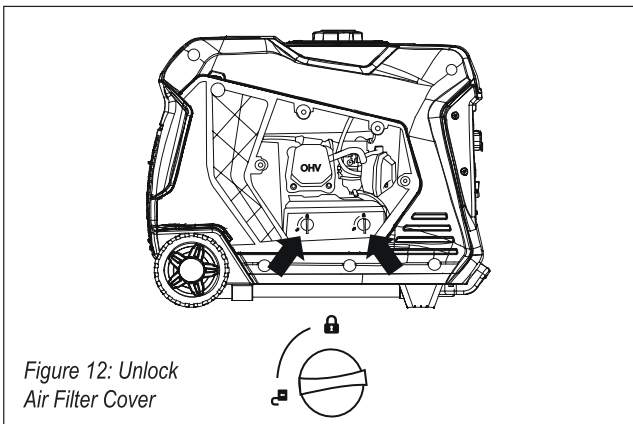

Figure 12: Unlock Air Filter Cover

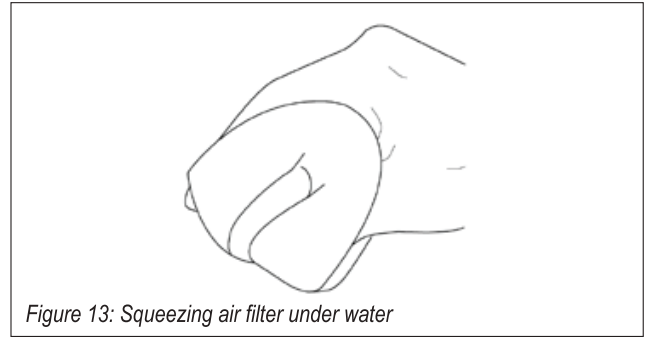

Figure 13: Squeezing air filter under water

4. Remove the foam element from the air cleaner housing.
5. Wash the foam air filter element by submerging the element in a solution of household detergent soap and warm water. Slowly squeeze the foam to thoroughly clean.

**NOTE:** NEVER twist or tear the foam air filter element during cleaning or drying. Only apply slow but firm squeezing action.

6. Rinse in clean water by submerging the air filter element in fresh water and applying a slow squeezing action (see Figure 13).

**NOTE:** Never dispose of soap cleaning solution used to clean the air filter by dumping the solution into a sewer, on the ground, or into ground water or waterways. Always be environmentally responsible.

Follow the guidelines of the EPA or other governmental agencies for proper disposal of hazardous materials. Consult local authorities or reclamation facility.

7. Dispose of used soap cleaning solution properly.
8. Dry the air filter element by again applying a slow firm squeezing action.
9. Return the air filter element to its position in the air cleaner housing.
10. Install the air cleaner cover, making sure the tabs lock into place.
11. Install the engine service panel.

## Draining the Float Bowl

1. Remove the Engine Service Panel to access the carburetor (see Figure 11).
2. Locate the clear plastic hose from the float that is extending towards the bottom of the generator, pull those hose outside the body and place a suitable container under it to catch the drained fuel (see Figure 14).

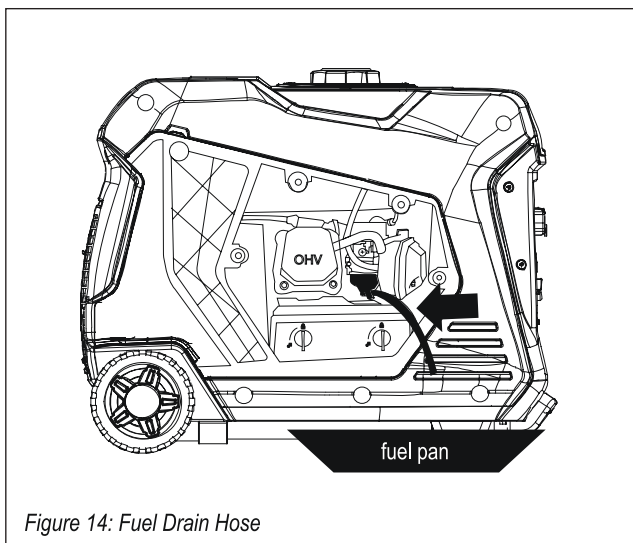

Figure 14: Fuel Drain Hose

3. Loosen the float bowl drain screw until fuel is seen draining from the float bowl (see Figure 12).

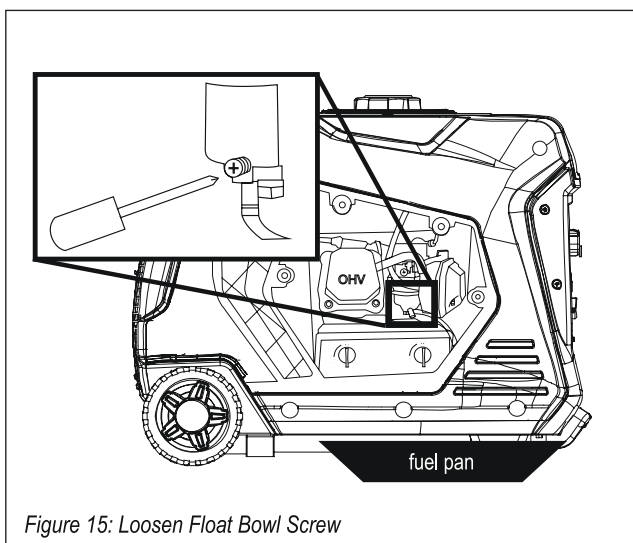

Figure 15: Loosen Float Bowl Screw

4. Allow fuel to drain into the container, and then tighten the float bowl drain screw.

**NOTE:** Never dispose of fuel by dumping fuel into a sewer, on the ground, or into groundwater or waterways. Always be environmentally responsible. Follow the guidelines of the EPA or other governmental agencies for proper disposal of hazardous materials. Consult local authorities or reclamation facility.

5. Install the engine service panel.

## Spark Plug Maintenance

The spark plug must be checked and cleaned after every 100 hours of use or 6 months and must be replaced after 300 hours of use or every year.

1. Stop the generator and let it cool for several minutes if running.
2. Move the generator to a flat, level surface.
3. Remove the Engine Service Panel to gain access to the spark plug (see Figure 11).
4. Remove the spark plug cover by firmly pulling the metal spark plug boot handle directly away from the engine (see Figure 16).

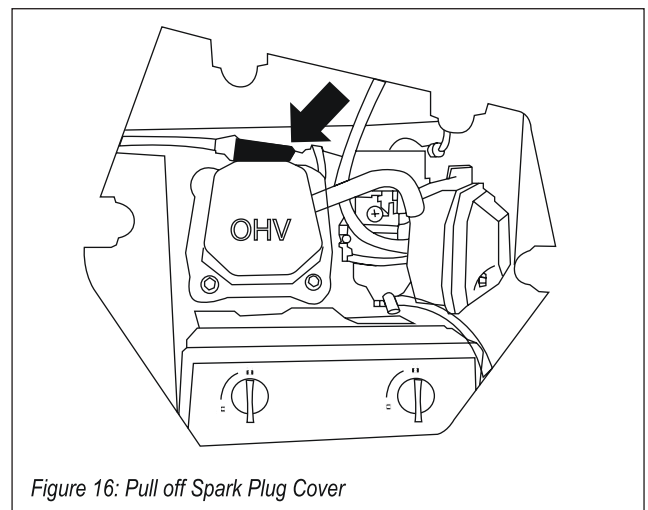

Figure 16: Pull off Spark Plug Cover

**NOTE:** Never apply any side load or move the spark plug laterally when removing the spark plug. Applying a side load or moving the spark plug laterally may crack and damage the spark plug boot.

5. Clean area around the spark plug.
6. Using the spark plug socket wrench provided, remove the spark plug from the cylinder head (see Figure 17).

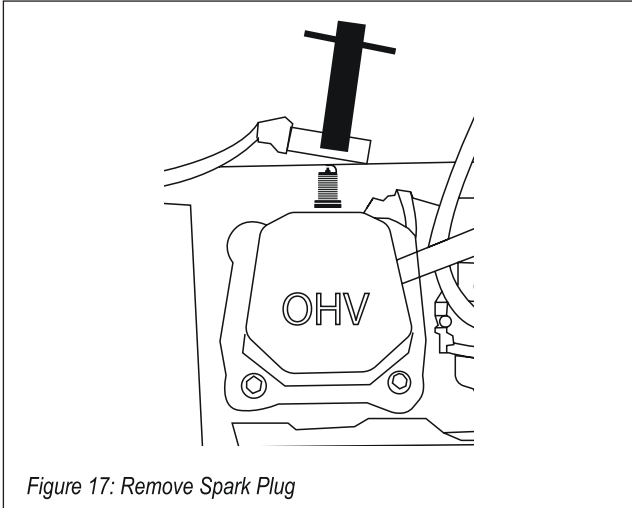

Figure 17: Remove Spark Plug

7. Place a clean rag over the opening created by the removal of the spark plug to make sure no dirt can get into the combustion chamber.

8. Inspect the spark plug for:

- Cracked or chipped insulator
- Excessive wear
- Spark plug gap of 0.032 in. (0.80 mm).

If the spark plug fails any one of the conditions listed above, replace the plug.

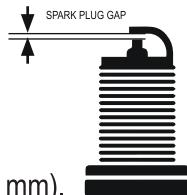

**NOTE:** Only use the recommended spark plug. See the following chart. Using a non-recommended spark plug could result in damage to the engine.

9. Install the spark plug by carefully following the steps outlined below:

- a. Carefully insert the spark plug back into the cylinder head. Hand-thread the spark plug until it bottoms out.
- b. Using the spark plug socket wrench provided, turn the spark plug to ensure it is fully seated.

- c. Replace the spark plug boot, making sure the boot fully engages the spark plug's tip.
- d. Install the spark plug access cover.

### Recommended Spark Plug Replacement:

Torch Spark plug	Champion	Bosch	Autolite
F7RTC	N9YC	W7DC	52

### Cleaning the Spark Arrestor

Check and clean the spark arrestor after every 100 hours of use or 6 months.

1. Stop the generator if running and let it cool for several minutes.

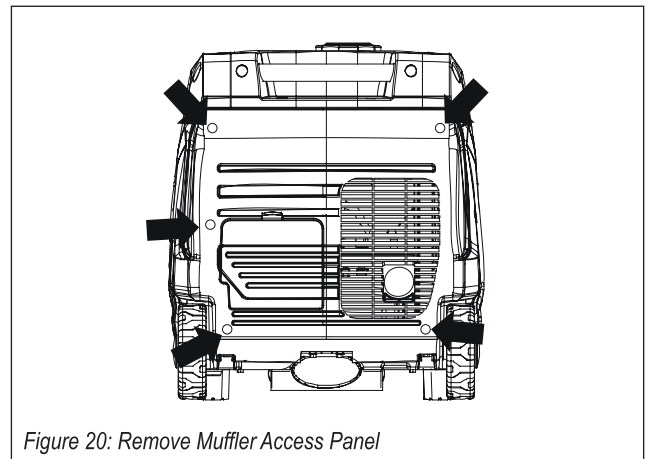

Figure 20: Remove Muffler Access Panel

2. Move the generator to a flat, level surface.
3. Remove the screws holding the muffler cover in place (see Figure 20).
4. Loosen the clamp holding the spark arrestor onto the muffler.
5. Slide the spark arrestor band clamp off the spark arrestor screen.
6. Pull the spark arrestor screen off the muffler exhaust pipe.

7. Using a wire brush, remove any dirt and debris that may have collected on the spark arrestor screen.
8. If the spark arrestor screen shows signs of wear (rips, tears or large openings in the screen), replace the spark arrestor screen.
9. Install the spark arrestor components in the following order:
  - a. Place spark arrestor screen over the muffler exhaust pipe. Push on the screen until it fully bottoms out.
  - b. Place the spark arrestor band clamp over the screen and tighten with a flathead screwdriver
10. Replace the discharge gate.

3. Rotate the engine to top dead center (TDC) of the compression stroke. Looking through the spark plug hole, the piston should be at the top.
4. Both the rocker arms should be loose at TDC on the compression stroke. If they are not, rotate the engine 360°.
5. Insert a feeler gauge between the rocker arm and the push rod and check for clearance (see Figure 22). See table below for valve lash specifications

### Standard Valve Lash

	Intake Valve	Exhaust Valve
<b>Valve Lash</b>	.0023-.0039in (.06-.10mm)	.0031-.0048in (.08-.12mm)
<b>Bolt Torque</b>	8-12N.m	8-12N.m

## Checking And Adjusting Valve Lash

### CAUTION!

*Checking and adjusting valve lash must be done when the engine is cold.*

1. Remove the rocker arm cover and carefully remove the gasket. If the gasket is torn or damaged, it must be replaced.
2. Remove the spark plug so the engine can be rotated more easily.

6. If an adjustment is required, hold the adjusting nut and loosen the jam nut.
7. Turn the adjusting nut to obtain the correct valve lash. When the valve lash is correct, hold the adjusting nut and tighten the jam nut to 106 in-lb (12 N•m).
8. Recheck the valve lash after tightening the jam nut.
9. Perform this procedure for both the intake and exhaust valves.
10. Install the rocker arm cover, gasket and spark plug.

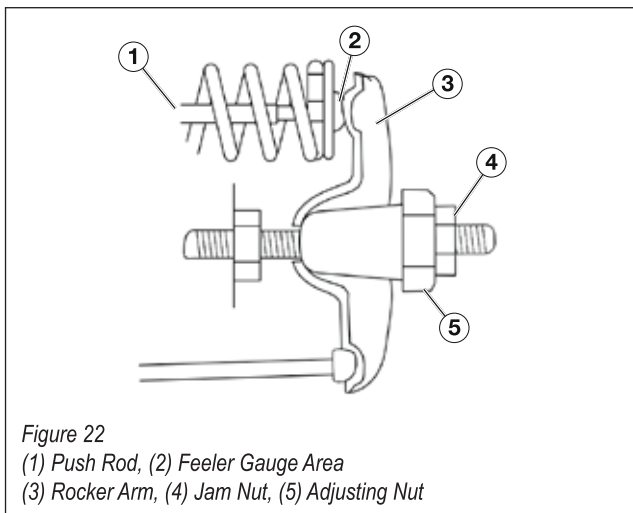

Figure 22  
 (1) Push Rod, (2) Feeler Gauge Area  
 (3) Rocker Arm, (4) Jam Nut, (5) Adjusting Nut

## Cleaning the Generator

It is important to inspect and clean the generator before every use.

### Clean All Engine Air Inlet and Outlet Ports

- Make sure all engine air inlet and outlet ports are clean of any dirt and debris to ensure the engine does not run hot.

## Battery Replacement

1. Remove the spark plug wire from spark plug.
2. Loosen the rubber strap holding the battery in place.
3. Disconnect the black negative (-) battery cable from the battery first.
4. Disconnect the red positive (+) battery cable second and remove the battery.

**NOTE:** Dispose of the used battery properly according to the guidelines established by your local or state government.

5. Install the new battery into the generator frame.
6. Connect the red positive (+) battery cable to the battery first.
7. Connect the black negative (-) battery cable to the battery second.
8. Replace rubber strap to hold battery in place.
9. Install the spark plug wire onto spark plug.

See below for the battery specification when replacing the battery.

After Market Battery Model	YT5AL
Volts	12
Amp Hr	5
Dimensions	4.63 x 2.38 x 5 inches

## Storage



### WARNING!

*Never store machine with fuel in the tank or in a poorly ventilated area where the fumes can come in contact with an ignition source such as a: 1) pilot light of a stove, water heater, clothes dryer or any other gas appliance; or 2) spark from an electric appliance.*

**NOTE:** Gasoline stored for as little as 60 days can go bad, causing gum, varnish and corrosive buildup in fuel lines, fuel passages and the engine. This corrosive buildup restricts the flow of fuel, preventing an engine from starting after a prolonged storage period.

Proper care should be taken to prepare the generator for any storage.

1. Clean the generator as outlined in the previous section 'Cleaning the Generator'.
2. Siphon all gasoline from the fuel tank as best as possible.
3. Start the engine and allow the generator to run until all the remaining gasoline in the fuel lines and carburetor is consumed and the engine shuts off.
4. Drain any remaining fuel from the float bowl. See 'Draining the Float Bowl' on page 18.
5. Change the oil (see 'Changing Engine Oil' on page 19).



## Troubleshooting

PROBLEM	POTENTIAL CAUSE	SOLUTION
Engine is running, but no electrical output.	1. Reset breaker is tripped.	1. Reset the reset breaker.
	2. The power cord's plug connector is not fully engaged in the generator's outlet.	2. Verify plug connector is firmly engaged in the generator's outlet.
	3. Faulty or defective power cord	3. Replace power cord.
	4. Faulty or defective electrical appliance	4. Try connecting a known good appliance to verify the generator is producing electrical power.
Engine will not start or remain running while trying to start.	1. Generator is out of gasoline.	1. Add gasoline to the generator.
	2. Fuel flow is obstructed.	2. Inspect and clean fuel delivery passages.
	3. Dirty air filter	3. Check and clean the air filter.
	4. Low oil level shutdown switch is preventing the unit from starting.	4. Check oil level and add oil if necessary.
	5. Spark plug boot is not fully engaged with the spark plug tip.	5. Firmly push down on the spark plug boot to ensure the boot is fully engaged.
	6. Spark plug is faulty.	6. Remove and check the spark plug. Replace if faulty.
	7. Dirty/plugged spark arrestor	7. Check and clean the spark arrestor.
	8. Stale fuel	8. Drain fuel and replace with fresh fuel.
Generator suddenly stops running.	1. Generator is out of fuel.	1. Check fuel level. Add fuel if necessary.
	2. The low oil shut down switch has stopped the engine.	2. Check oil level and add oil if necessary.
	3. Too much load	3. Restart the generator and reduce the load.
Engine runs erratic; does not hold a steady RPM.	1. Dirty air filter	1. Clean the air filter (see pages 24-25).
	2. Applied loads maybe cycling on and off	2. As applied loads cycle, changes in engine speed may occur; this is a normal condition.
	3. If trying 1-2 above does not solve the problem, the cause might be a fault in the generator	3. Take the generator to your nearest authorized service dealer.

### WARNING!

*Before attempting to service or troubleshoot, the owner or service technician must first read the owner's manual and understand and follow all safety instructions. Failure to follow all instructions may result in conditions that can lead to voiding of the EPA certification or product warranty, serious personal injury, property damage or even death.*

**Parts Diagram**

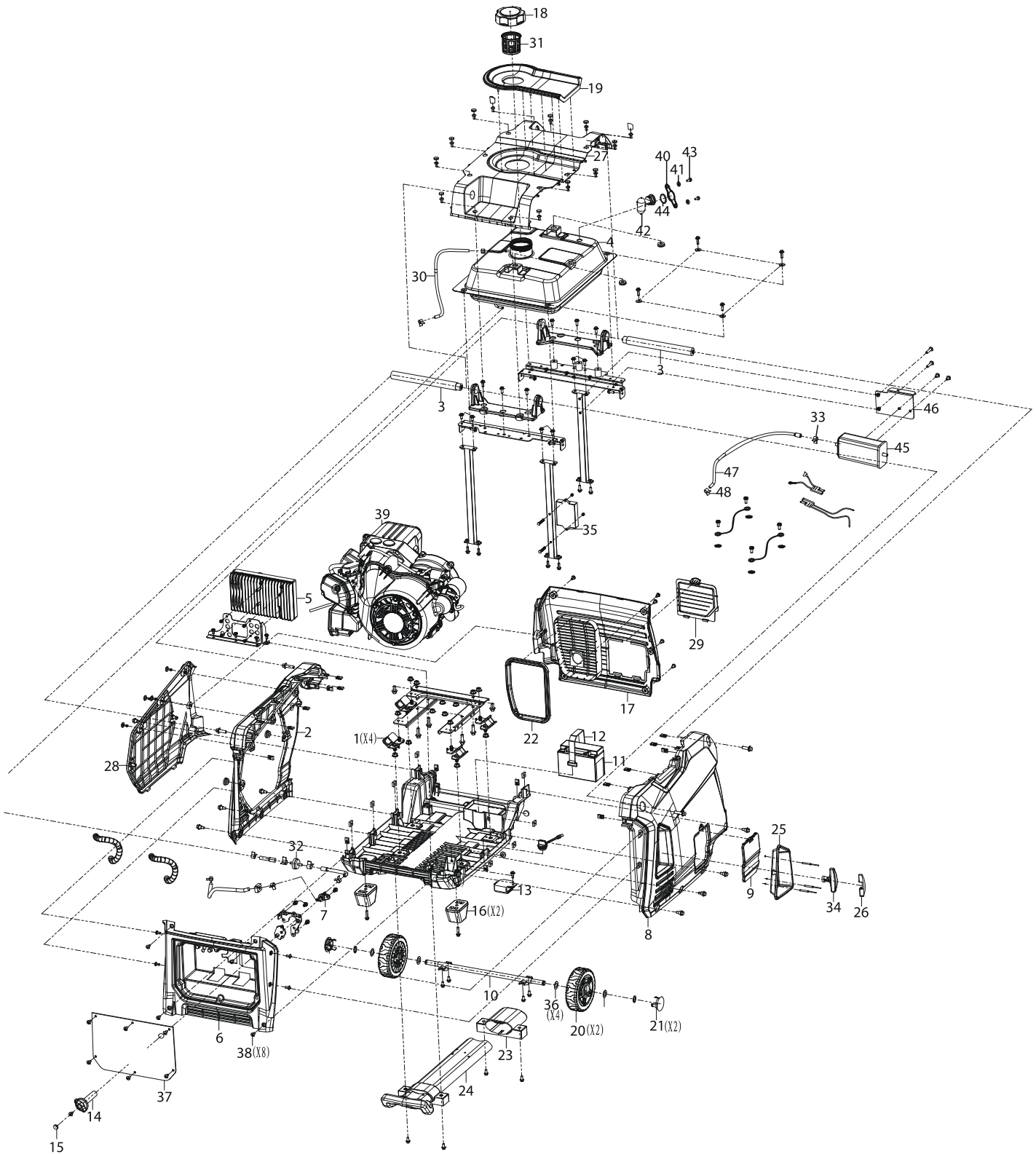

## Parts List

No.	Part.	Description
1	100578	Damper
2	100562	Enclosure Side
3	100567	Lift Bar
4	150526	Fuel Tank
5	120538	Inverter Module
6	100569	Intake Grate
7	150535	Fuel Valve
8	100563	Enclosure Side
9	100568	Inspection Cover
10	100574	Axle Shaft
11	100579	Battery
12	100580	Battery Clamp
13	130526	Voltage Regulator
14	150531	Fuel Knob
15	150533	Plug
16	100570	Rubber Foot
17	100564	Discharge Grate
18	150530	Cap
19	150528	Splash Guard
20	100571	Wheel
21	100577	Axle Cover
22	100565	Rubber Boot
23	100573	Handle Bracket
24	100572	Handle Assembly
25	170513	Grip Cup
26	170515	Recoil Anchor

27	100561	Enclosure Top
28	100560	Side Panel
29	100566	Access Cover
30	150527	Vent Hose
31	150529	Strainer
32	150534	Fuel Filter
33	150536	Hose Clamp
34	170514	Recoil Grip
35	130525	Controller
36	100575	Washer
37	130524	Control Panel
38	150532	M6X16
39	180578	Engine Assembly
40	150542	Clamp
41	150543	Gasket
42	150540	Fuel Level Sensor
43	150544	Bolt
44	150541	Gasket
45	150537	Carbon Canister
46	150538	Canister Bracket
47	150539	Vent Hose
48	150508	Hose Clamp

# Engine Parts Diagram

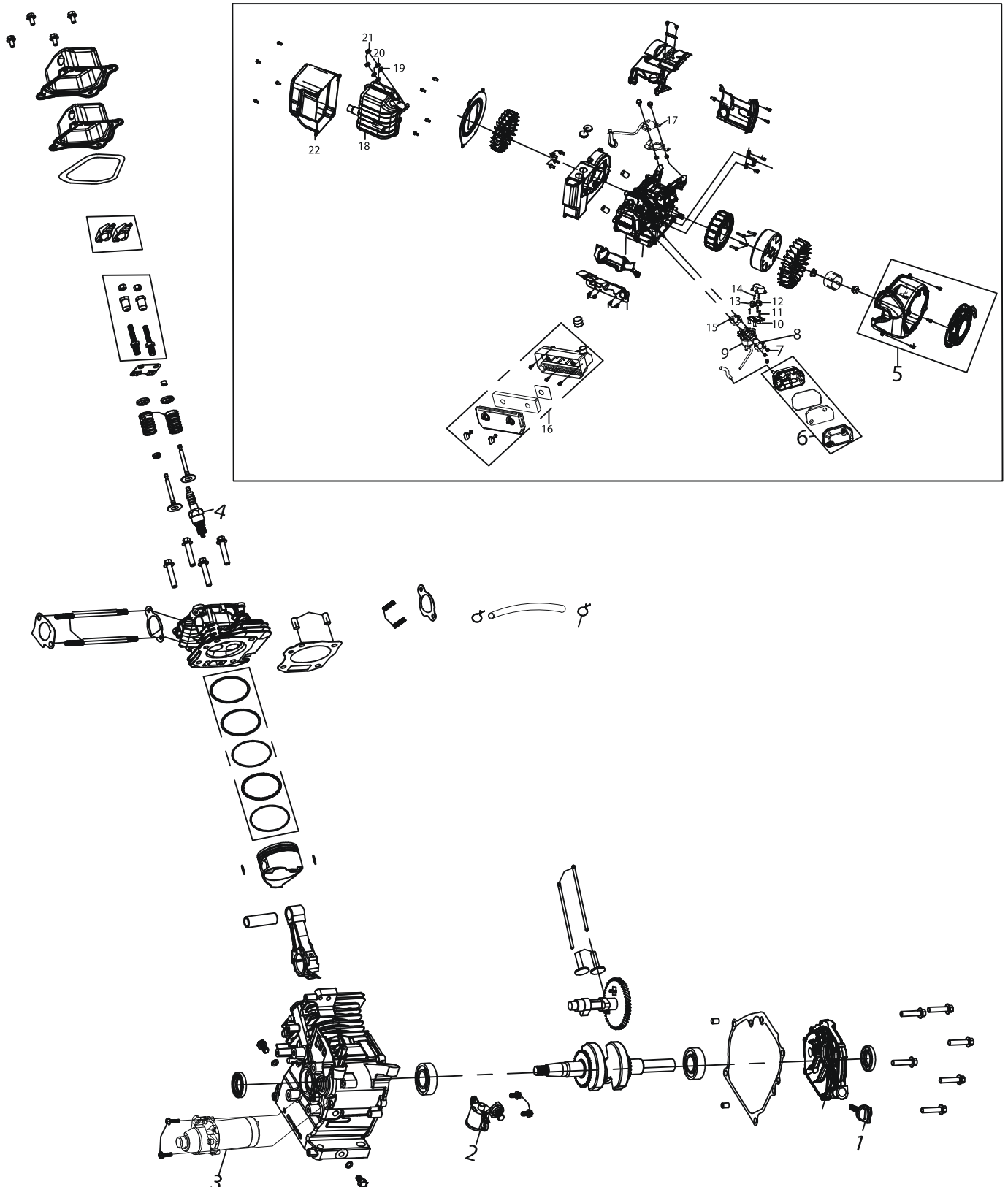

## Engine Parts List

No.	Part.	Description
1	180581	Dip Stick
2	180582	Low Oil Switch
3	170516	Starter
4	180580	Spark Plug
5	170512	Recoil and Housing
6	160504	Air Box
7	100548	M6 Nut
8	140517	Gasket
9	140532	Carburetor Assembly
10	140531	Stepper Motor Bracket
11	140533	M4X25
12	140529	Stepper Motor
13	140530	Stepper Motor
14	140534	M4X6
15	140535	Spacer
16	160504	Air Cleaner Assembly
17	180579	Ignition Coil
18	110510	Muffler Assembly
19	110512	Washer
20	110502	Spring Washer
21	180524	M8 Nut
22	110511	Heat Shield

## Wiring Diagram

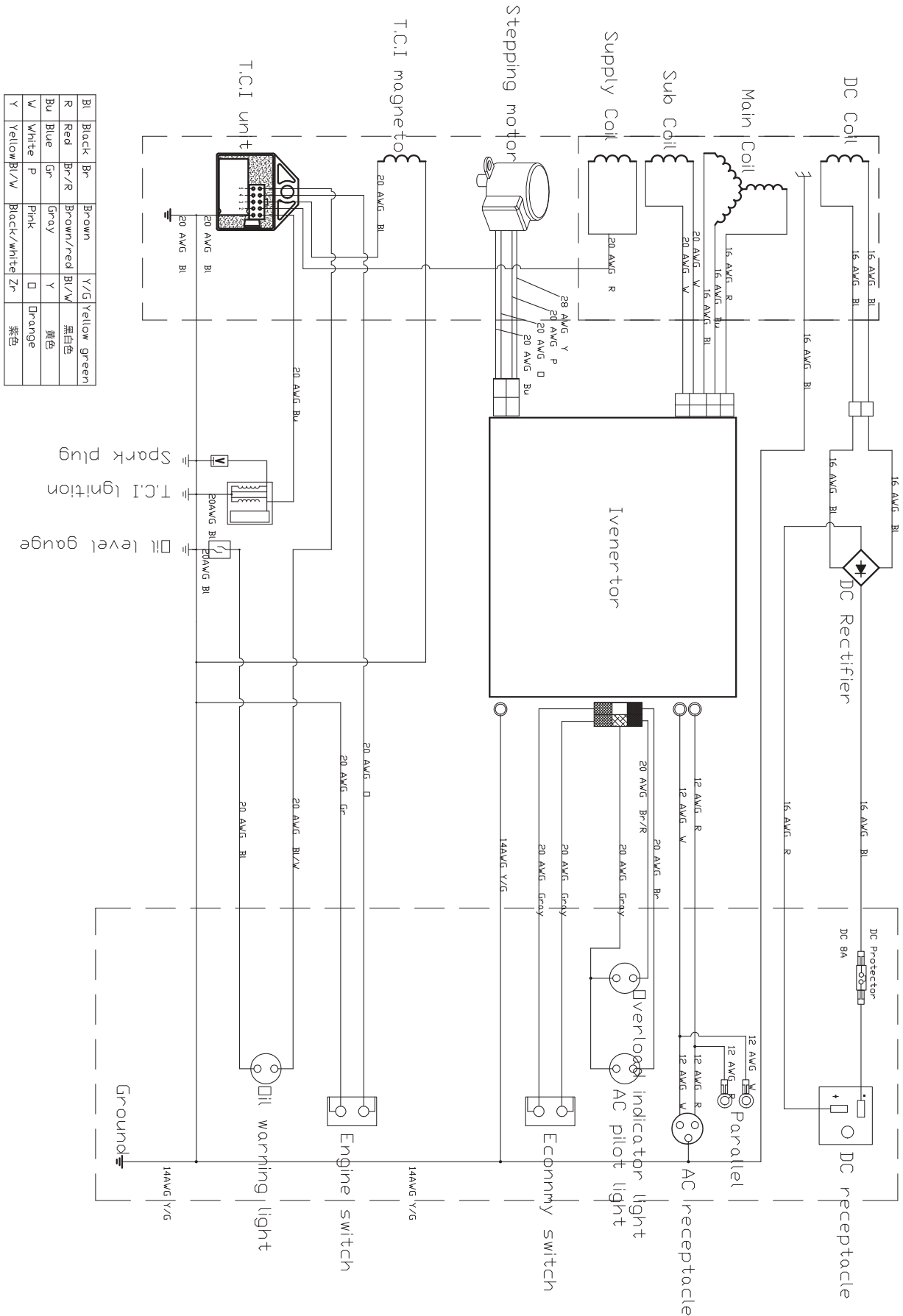

## Warranty

As part of an on-going commitment to excellence in product support, Euroquip offers a comprehensive product warranty program.

### 1. THIS WARRANTY:

The benefits provided to the consumer in this warranty are in addition to other rights and remedies of a consumer under the New Zealand Consumer Guarantees Act 1993 and any other laws in relation to the products to which this warranty relates. This warranty:

- Covers the product against faulty materials or workmanship; and
- Covers the replacement of parts, the repair labour used, a refund of the price of the product or replacement of the machine, or other compensation for the remainder of the warranty period.

This product warranty is only applicable to the original purchaser of the machine and only purchases made from Euroquip Authorized Retailers.

### 2) WARRANTY PERIODS:

**Commercial Warranty\*: 2 Years (24 months)**  
**Domestic Warranty\* : 4 Years (48 months)**

*Domestic Warranty applies to domestic use of the product: Personal, residential, or household use only. Commercial Warranty applies to commercial or business use of the product: All uses other than domestic use, including use for income-producing (including farming) or rental purposes.*

\*These GT Power Warranty periods are for products that are:

- Purchased from a New Zealand GT Power Dealer after 01/06/23
- Serviced by a GT Power Dealer in accordance with the GT Power service schedule, using genuine parts and the correct grade of oil (proof required)
- Meeting all other warranty requirements

**NOTE:** These warranty conditions apply to New Zealand only.

Euroquip warrants each new GT Power machine free from defect in material and workmanship under normal use and routine servicing, for the warranty periods specified. Conditional to the limitations and exclusions list below. The warranty period begins when the product is purchased by the end user. Warranty is not transferrable and is only claimable by the original purchaser.

Proof of purchase documentation with product serial number must be provided. If it has been lost and Euroquip does not have a record of the purchaser's details, the warranty period shall be calculated from the appropriate dealer wholesale sale date.

The purchaser must keep a record of all service and maintenance history as proof of servicing history. This may be requested when assessing any future warranty claims. The decision that an issue with a product qualifies as a warranty claim is made at the sole jurisdiction of Euroquip.

No costs incurred will be considered under warranty if repairs or maintenance are carried out by any party other than a Euroquip Approved Service Agent, unless with prior consent in writing from Euroquip.

It is the full responsibility of the purchaser to deliver the product under warranty to the nearest relevant service agent or product reseller. Warranty does not cover transportation costs including call outs, mileage and freight costs.

Customers are responsible for the care and cleaning of their product prior to sending it to our service centre. Any product being sent us must be thoroughly cleaned. Depending on what the product has come into contact with, it could pose an Occupational/ Work Health and Safety risk for our staff and or/service agents to inspect, repair or service a product that has come into contact with a hazardous substance. If we are asked to inspect, repair or service a product that has come into contact with a hazardous substance such as chemicals, asbestos or silica dust, we may not be able to inspect, service or repair the product. If this is the case, we will inform the purchaser and the product will be returned.

If a product is repaired under warranty, parts and labour required for the repair will be supplied at no charge. All defective parts replaced under warranty become property of Euroquip. Consumable items such as, but not limited to, oils, coolants, filter and spark plugs shall be the responsibility of the owner. Warranty assessment and repair will be scheduled and executed according to the normal work flow at the service location and depending on the availability of suitable replacement parts.

This warranty policy is an additional benefit and does not supersede the legal rights of any customer, reseller or service agent.

Should any issue be found to be a combination of a warranty failure and a non-warranty issue such as incorrect charging techniques, the repair cost component to rectify and repair the non-warranty failure is the **customer's** full responsibility.

### 3) EXCLUSIONS:

- Warranty does not cover parts that are subject to wear and tear from usage and/or damage which results from neglect of periodic maintenance.
- Evidence must be provided that the product has been maintained and serviced suitably for a claim to be considered under warranty.
- Batteries supplied with your product are warranted against defect for 3 months and does not include lack of charge due to non-use. Consumable items such as, but not limited to, oils, coolants, filters, spark plugs and batteries shall be the responsibility of the purchaser.
- Failure caused by incorrect operation of the product as specified in the manual either intentionally or by error.
- Lack of proper care and maintenance of the product.
- Any damage which results from unavoidable natural disasters, fire, collision, theft, etc.
- Any normal wear or deterioration, such as that of sliding or rotating parts caused under normal operating conditions.
- Any damage that results from misuse or use beyond the imitations of the products intended purpose (such as overloading or use under abnormal conditions).
- External circumstances such as product deterioration or corrosion due to environmental conditions like heat, cold, salt spray, sand or due to the passage of time
- Normal phenomena such as noise, vibration or oil seepage which are considered by Euroquip as not affecting the quality, function or performance of the product.
- Any damage due to improper storage or transport.
- Consumable replacement items: Spark plugs, contact points, shear pins, fuel strainers, oil filter elements, air cleaner elements, brake shoes or pads, clutch components, fuses, motor brushes, gaskets, tube or hoses, belts, cutting blades, light bulbs, serviceable bearings. Petroleum and others fluids: Oil, grease, battery electrolyte, and radiator coolant. Other items specified by Euroquip.
- Periodical maintenance items such as cleaning, inspection and adjustments.
- Contaminated fuel
- Modifications or installations of other products to the product
- Damage that results from the use of non-genuine parts, lubricant or fluid not approved by Euroquip
- Any repair and/or adjustment to correct improper or poor quality work previously performed.
- Attempted repair/ service by a party other than an Approved Service Agent, or any repair undertaken prior to approval of warranty by Euroquip is not covered under warranty.
- Warranty does not cover pre delivery service and adjustment, or failure that may occur as a result of lack of/ incorrect pre delivery service and adjustment. Warranty does not cover any incidental, indirect or consequential loss, damage, personal injury, or expense that may result from any defect, failure, malfunction, or misuse of a product.
- Any product that is found to have come into contact with hazardous substances such as chemicals, asbestos or silica dust and NOT been industrially cleaned prior to servicing.

### 4) HOW TO CLAIM WARRANTY:

In the event you are faced with a manufacturing fault with your GT Power product, you can claim a repair or part replacement under warranty if the following conditions are fulfilled:

- The problem is related to production quality or specifications of the machine
- The machine is within the warranty period outlined in schedule
- The issue does not fall within the warranty exclusions listed

If the criteria above is met, and you would like to request a warranty, then please go online to <https://www.euroquip.co.nz/Service-Request-End-User> and log your warranty claim.





# GT4000ESi ELECTRIC START INVERTER GENERATOR

---



Congratulations on your new GT POWER product. We are proud to have you as our customer and will strive to provide you with the best service and reliability in the industry. This product is backed by our extensive warranty and world-wide service network. Please contact your local agent or submit a service case online for fast response at [www.gtpower.co.nz](http://www.gtpower.co.nz)